

VISCO JET 

Trendsetting agitator technology

VISCO JET[®] column agitator VJ405

VISCO JET® column agitator VJ405

- Ideally suited for agitation or tinting of facade paints and plasters in round, or oval, single vessels from 5-50 litre
- VISCO JET® Pyramide impeller for effective agitation of products from low to high viscosities
- Simple change of mixing elements using the VISCO JET® fast release coupling
- Designed for professional use in continuous operation and in combination with automatic roller conveyor systems
- Secure vessel fixing using pneumatic clamping system with a vacuum gripper or a manual clamping device
- Drip tray prevents contamination of any parts
- Complete covering of the agitator with an aluminium housing meets the highest security and safety requirements
- Working and maintenance access via secured door with window
- Digital control unit with agitator process programming via touch screen



VISCO JET® VJ405

Easy to use for optimal integration into your production process



- Vessel is moved into the agitator housing via roller conveyor
- Vessel in operating position
- Locking of the vessel via manual or optionally pneumatic vessel clamping device
- Drip tray swivels to the side
- Selection of agitating program via touch screen or master control
- Start of the agitating process
- Agitating process completed
- Vessel is released, drip tray swivels back

VISCO JET® Pyramide -

We strike the right colour

After a very short time, the VISCO JET® Pyramide impeller, which is specially developed for this application, achieves the optimum tint and viscosity of your mixing medium during the agitating process.

This impeller can be used for tints and colours with viscosities up to 30.000 mPas.

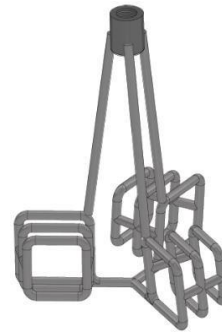

VISCO JET® VJ405

The semi-automatic column agitator for your production process

The VISCO JET® VJ405 is available in different versions to fulfil our customers' requirements.

	VJ405 Basic	VJ405 Basic+	VJ405 Pro
Article number	-	10055364	10050622
Drive	2,2 kW	2,2 kW	2,2 kW
Impeller	Pyramide	Pyramide	Pyramide
Column with electrical lift	✓	✓	✓
Position measuring system	---	✓	✓
Vessel clamping device	Manual	Manual	Pneumatic
Control unit	Kostal	Kostal	Siemens
Number of program options	10	10	10
Integration of master control	---	---	✓
Safety housing	✓	✓	✓
Protection guard / tunnel	✓	✓	Option
Roller conveyor	Option	Option	Option

Is there no suitable version for you?

Then give us a call or send us an e-mail, we look forward to configure a suitable agitator system together with you!

VJ405 accessories

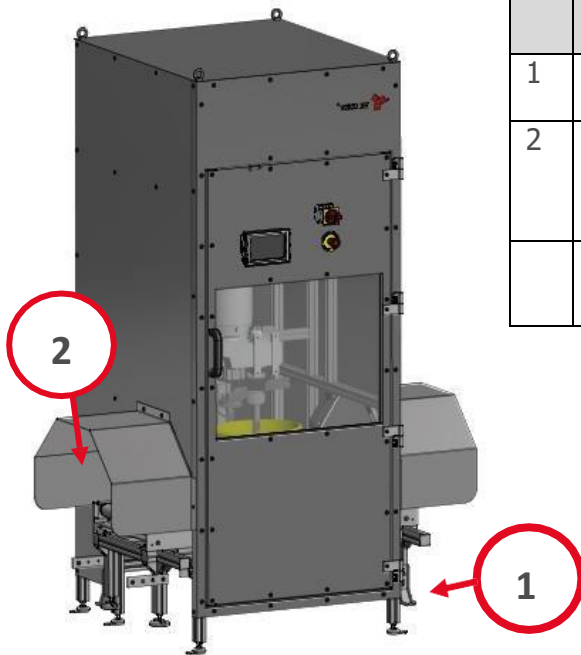

	Article	Description
1	10055376	Extension base frame VJ405
2	10055366	Safety guard for VJ405 Pro (2x per agitator needed)
	On request	Roller conveyor for VJ405

VISCO JET® is working for you around the world

VISCO JET® Rührsysteme GmbH

Mittlere Greut 2
79790 Küssaberg
Germany

Phone: +49 7741 91291 0

info@viscojet.com
www.viscojet.com

VISCO JET® GmbH

Bahnhofstraße 1
CH-5322 Koblenz/AG
Switzerland

Phone: +41 56 267 50 90

info@viscojet.ch
www.viscojet.ch

You can find your individual contact person on our website or give us a call!

